

## Grinder

### I. Competencies

Given a properly adjusted grinder, instruction and demonstration of use, each student will be able to :

- A. Identify the major parts of the grinder.
- B. Pass a written test on safety and operating procedures of the grinder with a minimum of 100 percent accuracy.
- C. Demonstrate, on a performance test, acceptable ability to use the grinder.

### II. Instructional Material and Procedures

#### A. Identification of Basic Grinder Parts:

- |                    |                                    |
|--------------------|------------------------------------|
| 1. Safety shield   | 6. Pedestal                        |
| 2. Spark deflector | 7. Motor                           |
| 3. Tool rest       | 8. Wheel guard                     |
| 4. Water pot       | 9. Dust chute                      |
| 5. Switch          | 10. Plane iron grinding attachment |

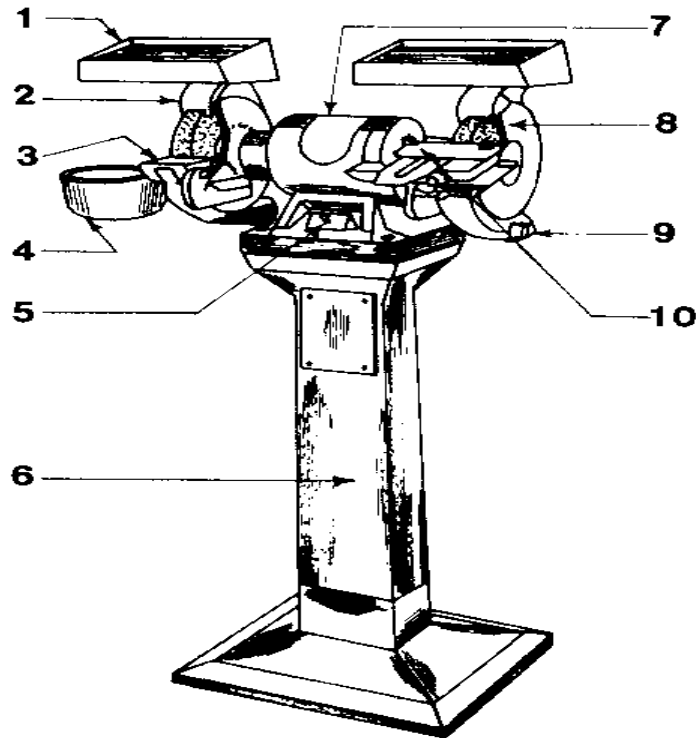

## B. Grinder Safety

1. Wear industrial quality eye protection and ear protectors.
2. Keep the tool rest adjusted as close as possible to the grinding wheel without touching it; never let the tool rest be more than 1/8 inch from the grinding wheel.
3. Always stand to the side when turning on the grinder. This will prevent the operator from being hit by wheel fragments if the grinding wheel should disintegrate when the grinder is turned on.
4. Make sure the wheel guards and safety shields are in place before using the grinder.
5. Grinding wheels which vibrate excessively should not be used. Dress such grinding wheels with the emery wheel dresser to make them turn true. If the wheel cannot be dressed check the grinder for a bent arbor. Do not continue to use a grinder with a bent arbor.
6. Wear a dust mask when truing a grinding wheel. Never breath the dust encountered when truing a grinding wheel.
7. When grinding do not put excessive pressure on the grinding wheel. Excessive pressure may cause pieces of the wheel to break and be thrown at the operator.
8. When grinding wheels are replaced make sure the replacement wheel's RPM specifications meet or exceed the capacity of the grinder.
9. Do not use grinding wheels when worn less than 1/2 of their original diameter. Replace the wheel when worn to 1/2 of the original diameter. When the grinding wheel is worn to the paper washer it should be replaced.
10. Do not grind on the side of a grinding wheel.
11. Do not wear gloves, loose fitting clothing or jewelry which may get caught between the grinding wheel and tool rest when grinding.
12. The tool rest should be adjusted such that grinding takes place at the center point or slightly above the center point on the grinding wheel.
13. The spark deflector should be adjusted to within 1/16 inch of the grinding wheel.

14. Make sure the operator can see the work well by keeping the safety shields clean and work lights functional.
15. Use the correct size arbor bushing when mounting a grinding wheel on a grinder.
16. Do not use the grinder if another person is within the grinder operating zone or in direct line of the grinding wheel action.
17. Make certain the grinder is turned off and has stopped rotating before leaving the operating zone.
18. If two people are using one grinder be careful not to bump the other person possibly causing him/her to hit the grinding wheel.

### C. Grinder Operating Procedures

1. When replacing a grinder wheel be sure to “sound” the wheel before it is installed. Take a piece of string and place it through the arbor hole of the grinding wheel. Hold the grinding wheel up by the string and tap it lightly with a metal object (nail). A ringing noise indicates the wheel is solid and usable, a dull sound indicates the wheel has an internal fracture and should be discarded.
2. The tool rest should be adjusted so that grinding can only take place on the upper one-half of the grinding wheel. Make sure the tool rest is perpendicular to the grinding wheel side and fastened securely.
3. True the grinder wheel when it becomes out of balance or when the surface becomes worn with grooves or rounded edges. Use the emery wheel dresser for truing the grinding wheel. Make several parallel passes back and forth across the face of the stone. Make sure the emery wheel dresser is held perpendicular (90 degrees) to the face of the grinding wheel.
4. Do not stand in direct line with the grinding wheel when using the grinder. Stand to the side so that if a piece of the grinder wheel is thrown off it will not hit you.
5. The metal being ground should be moved back and forth across the grinding wheel to produce an even wear pattern. Do not continuously grind in one spot on the grinding wheel.
6. Cool the metal often enough so the temper is not removed.

7. Allow the grinder to reach full operating speed before the grinding operation is started.
8. For fast cutting action a course grit grinding wheel should be selected; for finish grinding, a fine grit grinding wheel should be used. The smaller the grit number the coarser the grinding wheel cut. A 60 grit grinding wheel is recommended for most tool fitting.
9. When using grinding attachments on the grinder, be sure they are fastened securely and properly aligned.
10. Clean the safety shields often so the operator can see the work being ground.
11. The spark deflector is on the grinder to prevent sparks from being thrown toward the grinder operator. Keep it adjusted to within 1/16 inch of the grinding wheel for safest performance.

III. Written Test

**Grinder Safety and Operation Test**

Name \_\_\_\_\_ Date \_\_\_\_\_ Class \_\_\_\_\_

Multiple Choice – Place the letter of the most correct answer on the answer sheet.

1. A good grinding wheel will have a \_\_\_\_\_ sound when it is “sounded”.
  - a. dull
  - b. high pitch
  - c. ringing
  - d. low pitch
  
2. A fractured grinding wheel will have a \_\_\_\_\_ sound when it is “sounded”.
  - a. dull
  - b. high pitch
  - c. ringing
  - d. low pitch
  
3. Grinding should be done only on the \_\_\_\_\_.
  - a. left side of the grinding wheel
  - b. right side of the grinding wheel
  - c. upper one-half of the grinding wheel
  - d. lower one-half of the grinding wheel
  
4. A grinder tool rest should never be more than \_\_\_\_\_ inch from the grinding wheel.
  - a.  $\frac{3}{8}$
  - b.  $\frac{1}{4}$
  - c.  $\frac{3}{16}$
  - d.  $\frac{1}{8}$
  
5. When grinding, the operator should not stand \_\_\_\_\_.
  - a. in direct line with the grinding wheel
  - b. to the left side of the grinder
  - c. to the right side of the grinder
  - d. near the center line of the grinder

6. Grinding wheels which vibrate excessively do so because \_\_\_\_\_.
- a. they are out of round
  - b. the arbor shaft of the grinder is bent
  - c. both a and b
  - d. neither a nor b
7. The protective equipment item(s) which should be used when truing a grinding wheel is/are \_\_\_\_\_.
- a. safety glasses
  - b. gloves
  - c. dust mask
  - d. all of the above
  - e. a and c above
8. If excessive pressure is applied to the grinding wheel, it is likely to cause \_\_\_\_\_.
- a. a bent arbor
  - b. a distorted piece of metal
  - c. an overheated piece of metal
  - d. a chipped grinding wheel
9. If the arbor revolutions per minute (RPM's) of a given grinder is 3400, which grinding wheel would be safe for use on this particular grinder?
- a. 1700 RPM grinding wheel
  - b. 2400 RPM grinding wheel
  - c. 2800 RPM grinding wheel
  - d. 4600 RPM grinding wheel
10. The spark deflector on a grinder should be adjusted to within \_\_\_\_ inches of the grinding wheel.
- a.  $\frac{1}{4}$
  - b.  $\frac{1}{8}$
  - c.  $\frac{1}{16}$
  - d.  $\frac{1}{32}$

11. Before grinding, the operator should \_\_\_\_\_.
- a. allow the grinder to reach full operating speed
  - b. make certain others are not standing in line with the grinding wheel action
  - c. clean the grinder safety shields
  - d. a and b above
  - e. a, b and c above
12. Which of the following grinder wheels would cut the fastest?
- a. Fine grit
  - b. Medium grit
  - c. Course grit
  - d. They would all cut the same
13. A grinding wheel should be replaced when worn to \_\_\_\_\_ of it's original diameter.
- a.  $\frac{3}{4}$
  - b.  $\frac{1}{2}$
  - c.  $\frac{3}{8}$
  - d.  $\frac{1}{4}$
14. Which of the following grinding wheels would produce the smoothest grinding surface?
- a. 30 grit
  - b. 40 grit
  - c. 60 grit
  - d. 90 grit
15. The purpose of standing to the side when the grinder is turned on is to \_\_\_\_\_.
- a. to keep others out of the line of work
  - b. to keep from getting hit by flying debris
  - c. to make sure the grinder will come up to full operating speed
  - d. to make sure the wheel cover is on securely for the grinding operation to be performed





## Grinder Parts Identification

Name \_\_\_\_\_

Match the number of each grinder part with the correct part name.

- |                                       |                      |
|---------------------------------------|----------------------|
| ___ A. Water pot                      | ___ F. Switch        |
| ___ B. Motor                          | ___ G. Safety shield |
| ___ C. Plane iron grinding attachment | ___ H. Pedestal      |
| ___ D. Wheel guard                    | ___ I. Dust chute    |
| ___ E. Spark deflector                | ___ J. Tool rest     |

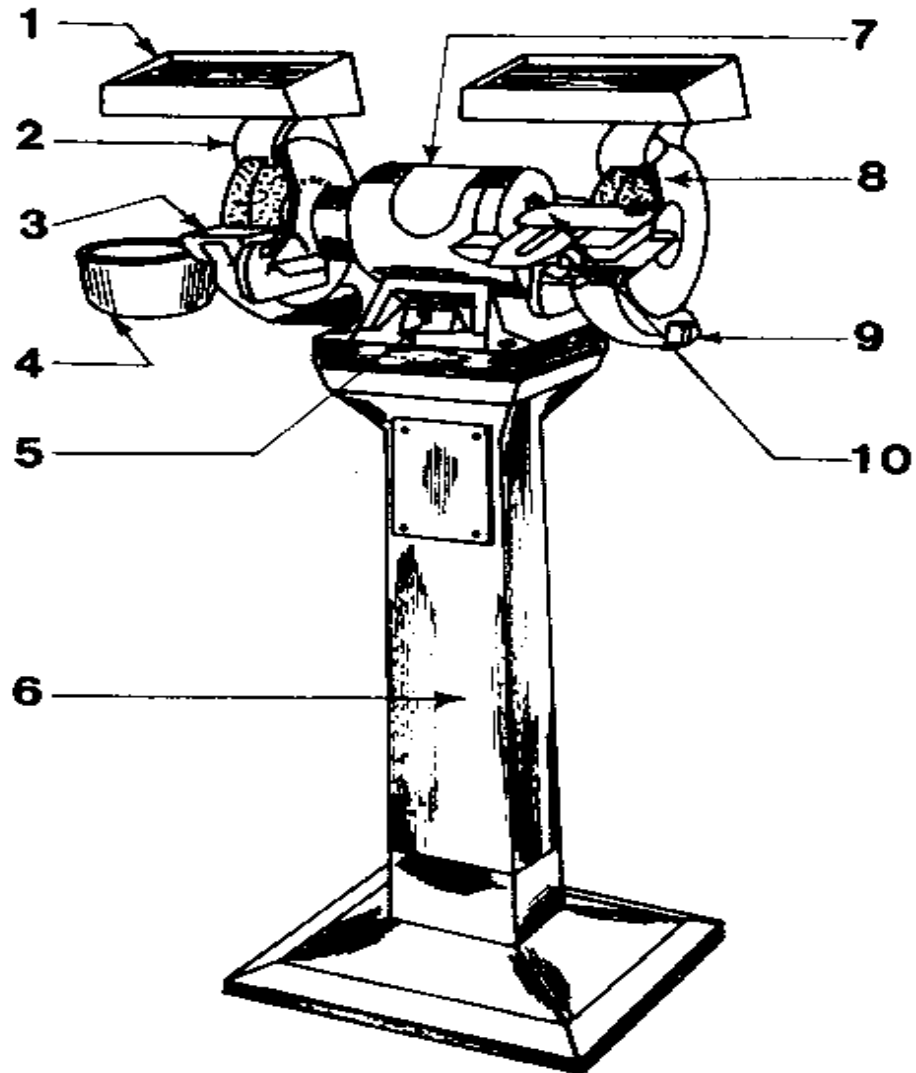

# BASIC GRINDER PARTS

