

Finishing Sander

I. Competencies

Given a properly adjusted finishing sander, accessories, instruction and demonstration of use, each student will be able to:

- A. Identify the major parts of the finishing sander.
- B. Pass a written test on safety and operating procedures of the finishing sander with 100 percent accuracy.
- C. Demonstrate ability to use the finishing sander, following suggested safety rules and correct operation procedures.

II. Instructional Materials and Procedures

A. Identification of basic finishing sander parts.

- | | |
|-------------------------|---------------------|
| 1. Brush Holder | 6. Paper Clamp |
| 2. Switch Lock | 7. Pad |
| 3. Trigger Switch | 8. Paper Clamp |
| 4. Handle | 9. Aluminum Housing |
| 5. Cord Strain Reliever | 10. Front Hand Knob |

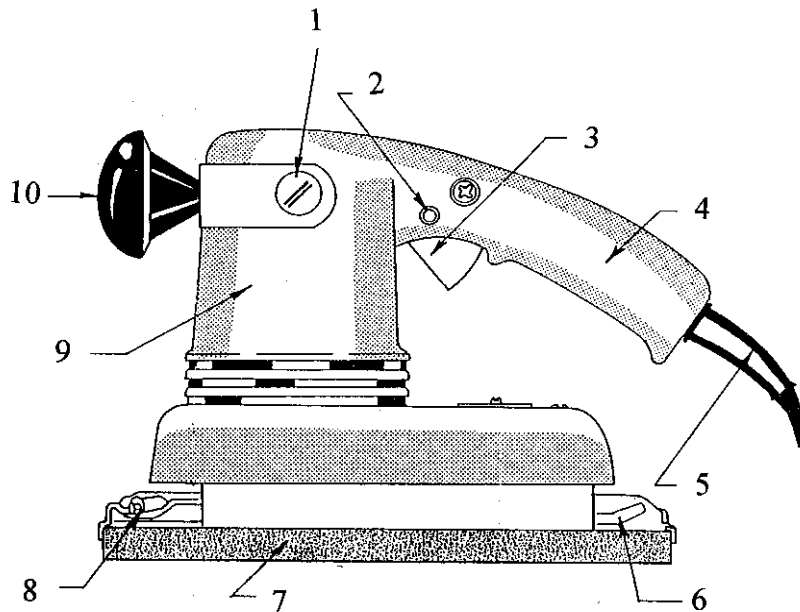

B. Finishing Sander Safety

1. Wear safety glasses at all times when using the finishing sander.
2. Wear a dust mask or respirator to prevent breathing the fine saw dust particles that are generated by the finishing sander.
3. Keep the electrical and extension cords away from the work area.
4. Wear hearing protectors when using finishing sanders that are noisy.
5. Secure or clamp the stock before starting the sanding operation.
6. Watch out for slick walking surfaces when using the finishing sander. Fine dust particles will settle on the floor making it slick.
7. Visually inspect the sander to make sure the electrical cord is not frayed or pulled out of the sander housing. If either condition exists repair the sander before using.
8. If the sander sparks excessively when being used check the brushes. Reseat or replace the brushes as necessary to reduce sparking.
9. Do not over-extend and get off balance when using the finishing sander.
10. If the sander has a metal housing make sure the electrical cord has a functional grounding terminal (round). If the grounding terminal has been cut off do not use the sander until the plug has been replaced.

C. Operating Procedures

1. Cut sand paper sheets in one third, one half, or on quarter as needed to fit the finishing sander pad you are using.
2. Mount the sand paper under the paper clamps on the sander pad. A tight fit will help to get longer sand paper life.
3. Hold the finishing sander over the stock, turn it on and allow it to reach full operating speed before starting the sanding operation.
4. Place the sander on the material and move it back and forth along the grain of the wood.
5. Do not apply additional down pressure on the sander when sanding. The weight of the sander creates sufficient sanding pressure for most applications.

6. If the finishing sander has a dust bag it should be emptied often for most efficient operation.
7. Start the sanding operation with coarse sand paper, then move to medium grit paper, and finish the sanding operation with a fine grit paper.
8. When finishing the sanding operation raise the sander off the stock and turn the switch off.

III. Written Test

Finishing Sander Safety and Operation Test

Name _____ Date _____ Class _____

Multiple Choice - Place the letter of the most correct answer on the answer sheet.

1. What personal protection equipment should be worn when operating the finishing sander?
 - a. Safety glasses
 - b. Dust mask
 - c. Hearing protectors
 - d. All of these

2. What happens to many walking surfaces in areas where finishing sanders are used?
 - a. They are difficult to see because of the saw dust covering.
 - b. They become slick because of the saw dust covering.
 - c. The saw dust chemically reacts with the floor finish making it slick.
 - d. None of these.

3. If a finishing sander sparks excessively when being used what should be done?
 - a. Readjust the pad.
 - b. Replace the drive bearing which causes the sander to orbit.
 - c. Inspect, recondition or replace the brushes.
 - d. Check the electrical cord for continuity.

4. If the electrical cord is pulled out of the sander housing what should be done with the finishing sander?
 - a. Repair the cord before using the sander further.
 - b. Wrap the cord with a good quality electrical tape.
 - c. Continue to use the sander until it stops running then have the cord repaired.
 - d. Cut the cord to prevent further use.

5. What does the grounding terminal look like on finishing sander?
 - a. Rectangular
 - b. Square
 - c. Round
 - d. Triangular

6. Finishing sanders use what size sand paper?
 - a. One-third sheet
 - b. One-quarter sheet
 - c. One-half sheet
 - d. All of these

7. How much pressure should the operator put on a finishing sander when sanding?
 - a. None
 - b. Light pressure
 - c. Medium pressure
 - d. Heavy pressure

8. What type of sandpaper should be used to complete most finishing sander jobs?
 - a. Course
 - b. Medium
 - c. Fine
 - d. Extra fine

IV. Performance Test for the Finishing Sander

The student performs the following while operating the finishing sander:

	Yes	No	N/A
1. Safety glasses are worn while the finishing sander is being used.	___	___	___
2. A dust mask and hearing protectors are worn when the finishing is being operated.	___	___	___
3. The finishing sander is held firmly in both hands when it is turned on and being used.	___	___	___
4. The finishing sander has stopped running before it is laid down.	___	___	___
5. The electrical and extension cords are positioned away from the work being performed.	___	___	___
6. The electrical cord is unplugged when the sandpaper is replaced on the finishing sander.	___	___	___
7. The student can select, remove, and replace sandpaper on the finishing sander.	___	___	___
9. The student can safely control the finishing sander and perform satisfactory sanding work.	___	___	___

I do hereby certify that the student has satisfactorily demonstrated ability to operate the finishing sander by passing this performance test.

Student Date Teacher Date

Finishing Sander Parts Identification Test

Name _____

Match the number of each finishing sander part with the correct part name.

- | | |
|-----------------------------|-------------------------|
| ___ A. Trigger Switch | ___ F. Paper Clamp |
| ___ B. Switch Lock | ___ G. Pad |
| ___ C. Handle | ___ H. Aluminum Housing |
| ___ D. Cord Strain Reliever | ___ I. Front Hand Knob |
| ___ E. Brush Holder | ___ J. Paper Clamp |

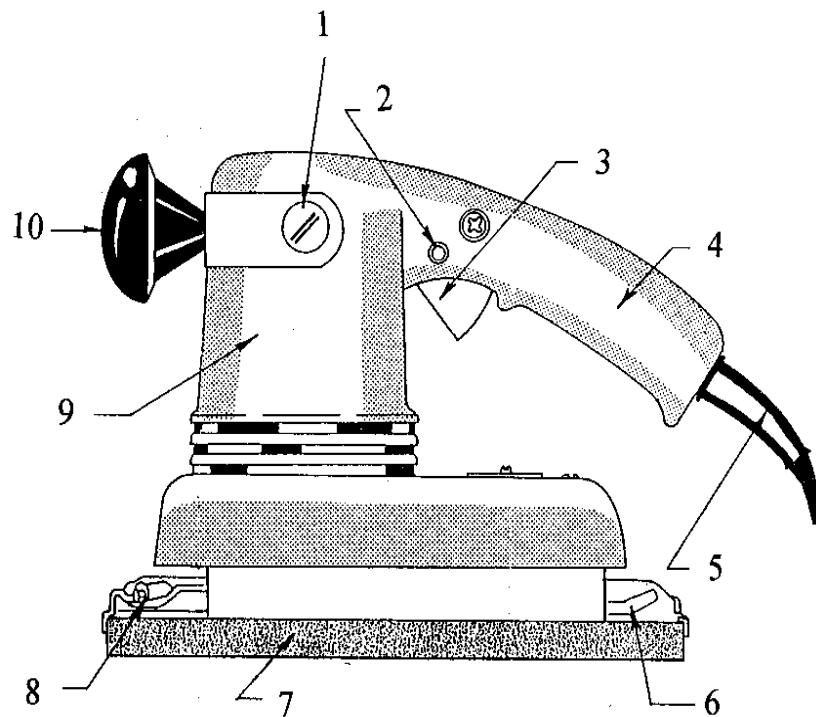

Finishing Sander

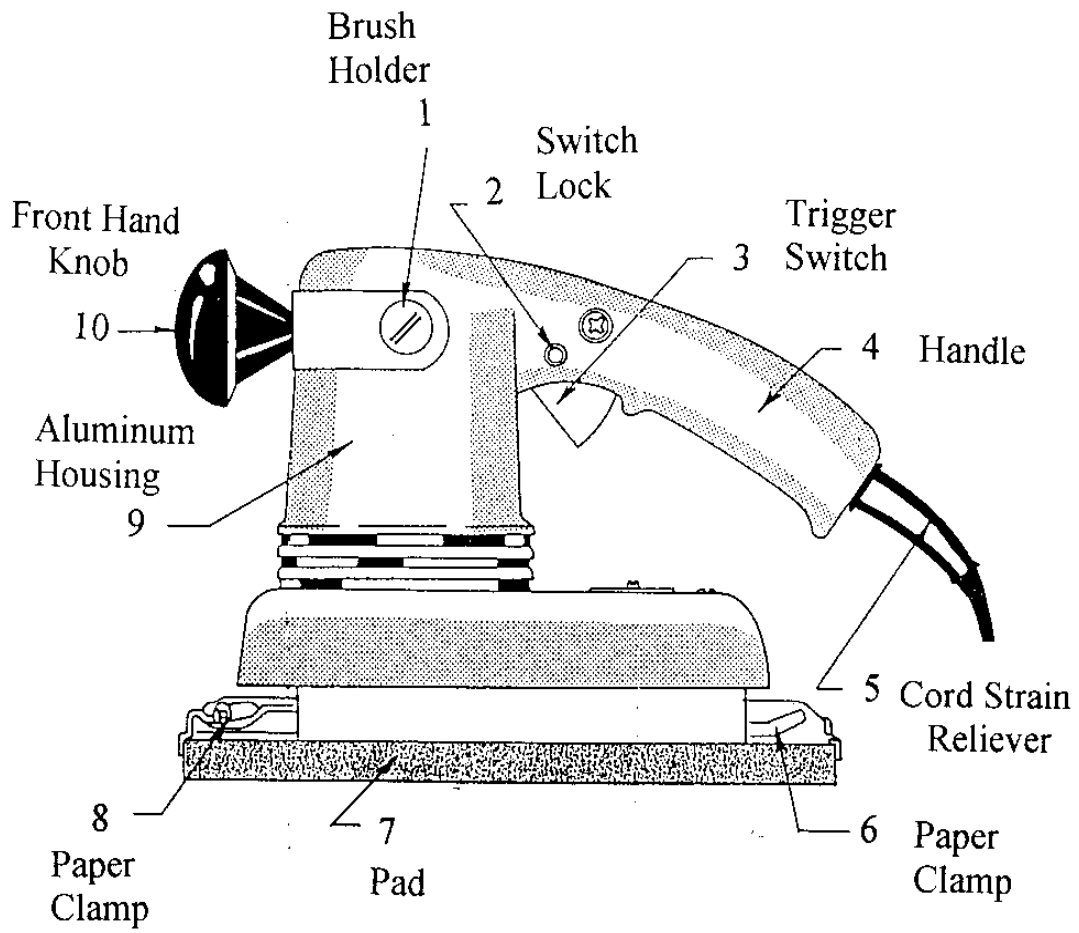

Finishing Sander

