

Band Saw

I. Competencies

Given a properly adjusted band saw, instruction and demonstration of use, each student will be able to:

- A. Identify the major parts of the band saw.
- B. Pass a written test on the safety and operating procedures of the band saw with 100% accuracy.
- C. Demonstrate the ability to use the bandsaw while observing all safety rules and correct operating procedures.

II. Instructional Materials and Procedures

A. Identification of Basic Bandsaw Parts

- | | | |
|---------------------------|------------------------------|-------------------------|
| 1. Blade Tensioning Screw | 6. Table Insert | 12. Guide Locking Screw |
| 2. Blade Cover | 7. Table Angle Scale | 13. Blade Guides |
| 3. Arm | 8. Switch | 14. Blade Slot |
| 4. Thrust Bearing | 9. Work Lamp | 15. Miter Gage |
| 5. Table | 10. Guide Post | 16. Slot |
| | 11. Guide Post Locking Screw | |

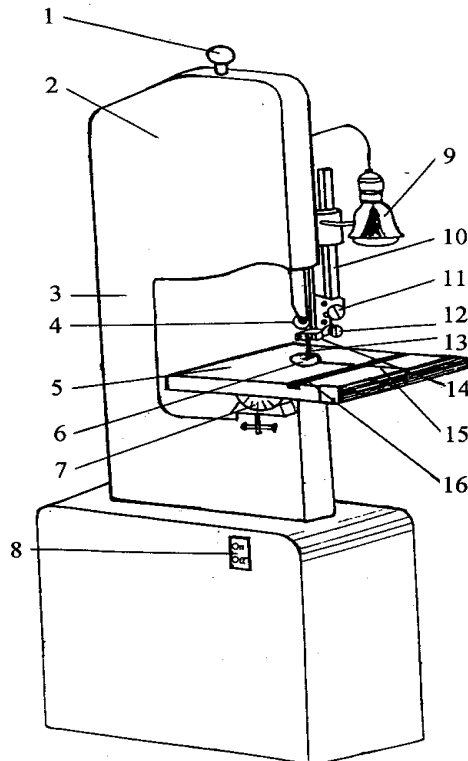

B. Band Saw Safety

1. Remove tie, rings, watch, and other jewelry, and roll up sleeves above the elbows. Remove all loose outer clothing and confine long hair. Protective type footwear should be worn. Do not wear gloves when operating the bandsaw.
2. Wear an approved safety shield, goggles or glasses to protect the eyes.
3. Keep the table and floor around the machine clean and free of scrap material, chips, oil, grease, coolant, tools or accessories to minimize the danger of slipping or tripping.
4. Keep guards in place at all times. The blade guard should be from 1/8 to 1/4 inch above stock. Keep hands away from blade and do not open upper or lower bandsaw doors while blade is in motion. Maintain a balanced stance and keep your body under control at all times; do not overreach.
5. Use only blades that are in good condition. Blades that are not sharp or have missing teeth can require excessive force and increase the chance of an accident.
6. Make all adjustments with the power off. Disconnect the power for any service, maintenance or blade changes on the bandsaw.
7. Give the work your undivided attention. Looking around, carrying on a conversation and horseplay are careless acts which can result in serious injury.
8. Upon completion of a job, clean the bandsaw and work area. Never clean the machine with the power on and never use hands to clean up chips and saw dust; use a brush.
9. Do not allow the hand or fingers to come closer than 2 inches to the blade.

C. Bandsaw Operating Procedures

1. Select the proper blade width, refer to a chart which gives the blade width for minimum radii cuts.
2. The teeth on the blade of a properly installed bandsaw should point downward in the direction of blade travel.
3. Check tension and tracking of the blade frequently, make adjustments as needed. Disconnect power and turn wheels by hand to see if the blade is tracking in the middle of the wheel.
4. Be sure material being sawed is free of nails, paint and other obstructions.
5. Plan your cuts carefully. Lay out work clearly, use relief cuts, and avoid backouts.
6. Do not cut stock until the machine is running at full speed.
7. Always place stock flat on the bandsaw table.

8. Do not force the stock into the blade at a rate faster than it can be readily cut.
9. If sawing freehand, use one hand to guide the stock into the blade and the other hand to push the stock into the blade. **DO NOT PUSH STOCK WITH HANDS IN LINE WITH THE BLADE.**
10. Do not place excess stress on the blade by twisting the stock, cut curves gradually.
11. If a problem develops and the blade has to be backed out, shut off the machine and wait until the blade has stopped.
12. If the blade breaks, shut off the power and move away from the machine. Never try to free a blade while the wheels are turning.
13. An indication of a cracked blade is a rhythmic click as the cracked portion of the blade passes through the wood.
14. Cylindrical stock should be mounted in a holding device to keep it from spinning and crowding the blade while being cut.
15. Make sure the band saw has stopped before leaving it.

III. Written Test

Bandsaw Safety and Operations Test

NAME _____ DATE _____ CLASS _____

Multiple choice – Place the letter of the most correct answer on the answer sheet.

1. The guards on the band saw should be adjusted to be approximately _____.
 - a. 1/16 to 1/8 inch above the stock
 - b. 1/8 to 1/4 inch above the stock
 - c. 1/4 to 1/2 inch above the stock
 - d. 1/2 to 1 inch above the stock

2. When sawing small stock, you should always use a _____.
 - a. push stick
 - b. line guard
 - c. hand rail
 - d. round guide

3. The blade on the band saw should be installed with the teeth pointing _____.
 - a. downward for cutting hardwood only
 - b. upward for cutting softwood only
 - c. upward for cutting both softwood and hardwood
 - d. downward for cutting both softwood and hardwood

4. Relief cuts are cuts made with the band saw. They _____.
 - a. are cuts made in a hurry
 - b. prevent the blade from binding
 - c. are special cuts for hardwood
 - d. are special cuts for softwood

5. In freehand cutting on the band saw, it is safe to _____.
 - a. hold round stock in the hand
 - b. force stock around the curves
 - c. place stock flat on the table
 - d. back out of curved cuts

6. It is safe to place the hand in line with the blade of the band saw _____.
 - a. only when the machine is not operating
 - b. only when the hand is more than 2" from blade
 - c. only when the hand is more than 4" from blade
 - d. only when the hand is more than 6" from blade

7. While operating the band saw, it is a safe practice to _____.
- open bandsaw covers very carefully
 - reach across material being cut on table
 - maintain a balanced stance at all times
 - wait until the end of class to clean up scraps
8. Which of the following is the correct procedure to determine if the blade is operating on the middle of the band saw wheel?
- Turn the wheel by hand to check
 - Turn on power for very short periods
 - Open wheel covers while it is coasting
 - Open wheel covers as brake is applied
9. When you give work your individual attention, you _____.
- look around
 - talk to your helper
 - concentrate on the work at hand
 - think about assignment for next period
10. The correct blade width to use for a specific job depends on _____.
- how fast you want to cut
 - the radius of the cut
 - what blade is available
 - type of material to be cut
11. The best time to remove scrap material from the band saw is _____.
- when the saw stops
 - as you work
 - after excessive scrap build-up
 - depends on job
12. If necessary to back the blade out of a cut _____.
- leave the power on so it comes out smoothly
 - turn the power off and then free the blade
 - leave the power on and loosen the blade tension
 - leave the power on but use brake to reduce speed
13. If too much cutting pressure has to be applied to get a cut, the blade _____.
- is dull
 - is too loose
 - needs readjusting
 - guides need adjusting

14. If you hear a rhythmic click as the wood is being cut, this usually indicates that:

- a. tension is too tight
- b. tension is too loose
- c. blade is cracked
- d. blade is hardened

15. If the blade breaks on the band saw, shut off the power and _____.

- a. try to remove blade
- b. put on the brake
- c. move away quickly
- d. remove your work

IV. Performance Test for Band Saw

Student _____

The student performs the following while using the band saw:

	Yes	No	N/A
1. Safety glasses are worn.	___	___	___
2. Safety guards are kept in place.	___	___	___
3. The table is cleared of other materials.	___	___	___
4. Clothing and jewelry are not hazardous.	___	___	___
5. The guard is 1/8-1/4 inch above stock.	___	___	___
6. The stock is fed properly into band saw.	___	___	___
7. All adjustments are made with power off.	___	___	___
8. The band saw and the work area are cleaned after use.	___	___	___
9. Work procedures are safe and acceptable.	___	___	___
10. Correct procedures are used when cutting stock.	___	___	___

Comments _____

I do hereby certify that the student has satisfactorily demonstrated the ability to operator the band saw by passing the above performance test.

Signed (Student) Date Signed (Teacher) Date

BANDSAW PARTS IDENTIFICATION TEST

Name _____

Match the number of each band saw part with the correct part name.

- | | | |
|--|------------------------------|--------------------------------------|
| ___ 1. Work
Lamp | ___ 7. Miter
Gage
Slot | ___ 13. Blade
Tensioning
Screw |
| ___ 2. Thrust
Bearing | ___ 8. Switch | ___ 14. Guide
Locking
Screw |
| ___ 3. Guide
Post
Locking
Screw | ___ 9. Table | ___ 15. Table
Angle
Scale |
| ___ 4. Guide
Post | ___ 10. Blade
Cover | ___ 16. Table
Insert |
| ___ 5. Blade | ___ 11. Blade
Guides | |
| ___ 6. Arm | ___ 12. Blade
Slot | |

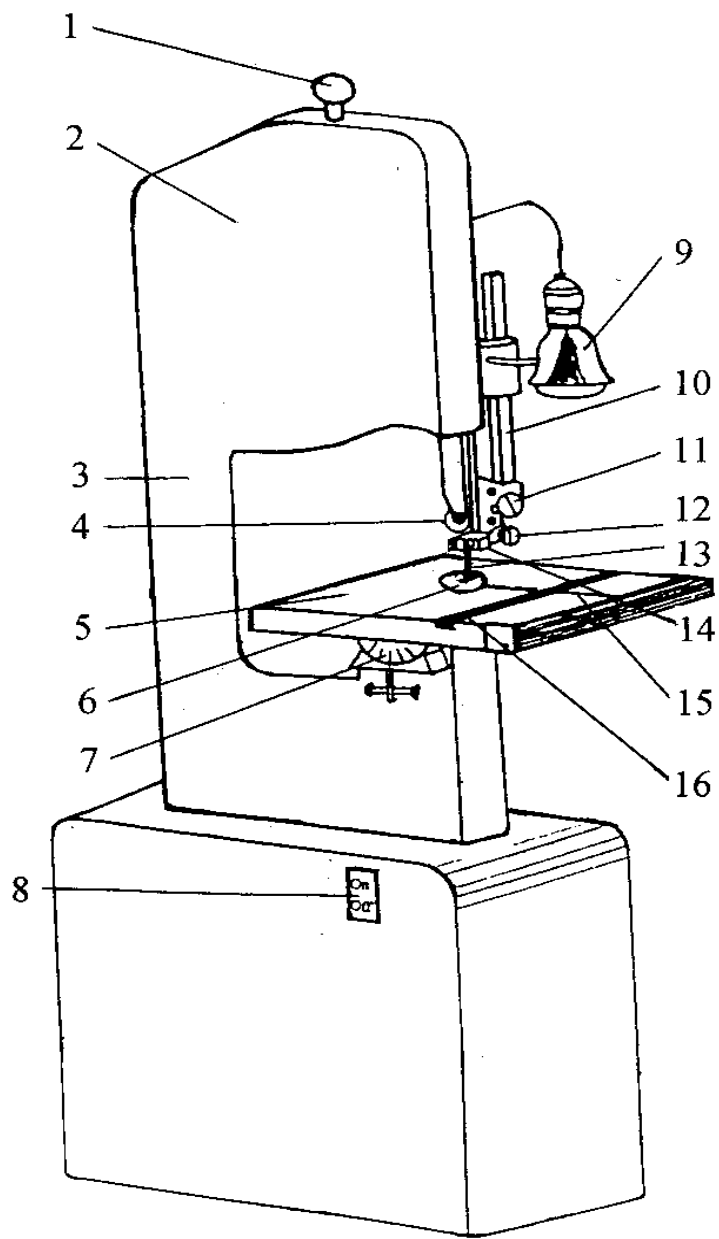

Band Saw Parts

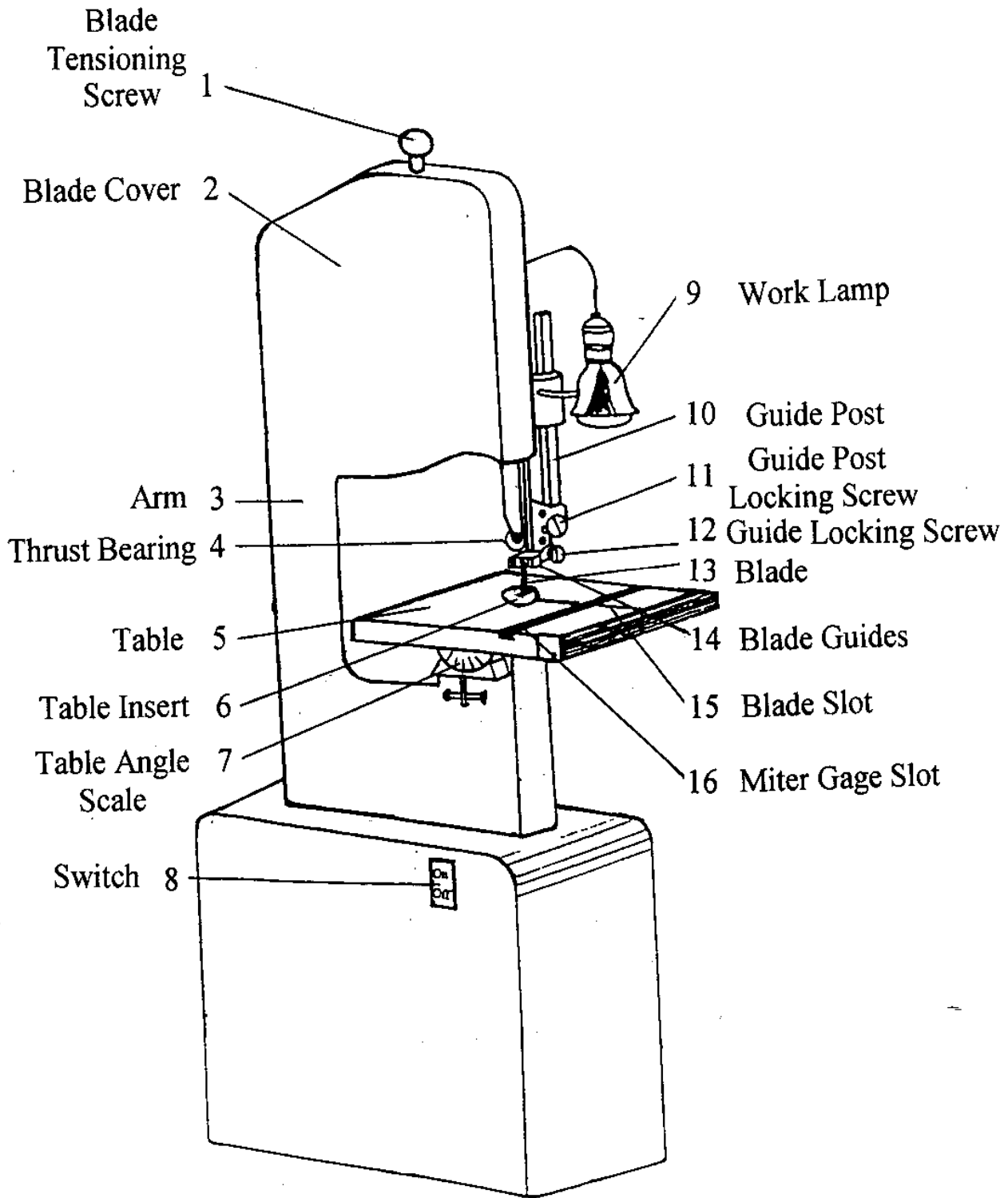

Band Saw Parts

